

SpecSeal® Closet Flange Firestop Gasket

SpecSeal® Closet Flange Firestop Gasket is a one-piece, molded rubber, intumescent pad that installs beneath a 3 in (76 mm) or 4 in (102 mm) closet flange to effectively firestop the opening. The die cut rubber gasket is perforated to delineate removable inserts sized to accommodate various outer diameters of toilet flanges.

Traditional firestopping methods require the firestop material to be applied around the pipe prior to setting the toilet flange, which can be problematic if the firestop material is not recessed a sufficient distance from the top to accommodate the throat of the flange. The alternative is to apply the firestopping from the underside of the floor, necessitating the use of ladders or lifts. SpecSeal® Closet Flange Firestop Gaskets solve the problem by providing a labor-friendly method of properly firestopping the opening.

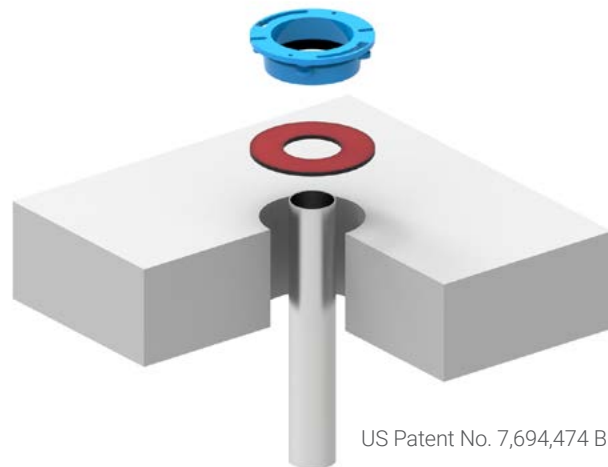

US Patent No. 7,694,474 B1

Applications

SpecSeal® Closet Flange Firestop Gaskets are designed to allow the drain pipe connected to a toilet flange to be properly firestopped without the need for firestop caulk for typical floor assemblies with plastic or metal pipes.

Specifications

The firestop system for the toilet flange shall be a molded, one-piece intumescent gasket with removable inserts to accommodate various outer diameters of toilet flanges certified by Underwriters Laboratories Inc. (UL) as a fill, void, or cavity material when tested to ASTM E814 (ANSI/UL1479) or CAN/ULC-S115 for up to a 2 hr. rating.

Specified Divisions

Division 7	07 84 13	Penetration Firestopping
Division 22	22 00 00	Plumbing
Division 23	23 00 00	HVAC

Performance

SpecSeal® Closet Flange Firestop Gaskets have been successfully tested in accordance with ASTM E814 (ANSI/UL1479) and CAN/ULC-S115 in one and two hour fire-rated floor assemblies. Consult factory for individual system designs and application requirements.



Maintenance

None typically required. Any damage observed should be repaired using SpecSeal® Firestop Products.

System Selection

To find your firestop system or create a submittal, visit <https://systems.stifirestop.com/> to use System Search & Submittal Builder. You may also visit the [UL Online Certifications Directory/UL Product iQ™](#) for complete listings. (Firestop Systems).

Technical Service

Specified Technologies Inc. provides toll free technical support to assist in product selection and appropriate installation design. UL System designs suitable for submittal or specification purposes are available on request. A complete library of technical information is provided at the company's website www.stifirestop.com including Safety Data Sheets (SDS's).

PHYSICAL PROPERTIES

Color	Red
Thickness	1/4" (6 mm)
Weight	0.13 lbs (0.06 kg)
Expansion Begins	320°F (160°C)
Volume Expansion	800%
Storage Temperature	Less than 130°F (54°C)
In-Service Temperature	Less than 130°F (54°C)
Shelf Life	No Limit

Precautionary Information

No unusual hazards are known or expected. Observe normal safety procedures during installation.

Availability

SpecSeal® Closet Flange Firestop Gaskets are available from Specified Technologies Inc. (STI) authorized distributors. For additional purchasing and technical information or for the names and locations of the nearest representative and/or distributor, regarding this and other Specified Technology products, please call 1-800-992-1180 or visit www.stifirestop.com.

ORDERING INFORMATION

Catalog Number	UPC Number	Description	(UOM) Qty.	Case Qty.	Weight (Each)
CF34	73057303780	Gasket sized for 3" (76 mm) or 4" (102 mm)	1	10	0.20 lbs (0.09 kg)

IMPORTANT NOTICE: ALL STATEMENTS, TECHNICAL INFORMATION, AND RECOMMENDATIONS CONTAINED HEREIN ARE BASED UPON TESTING BELIEVED TO BE RELIABLE, BUT THE ACCURACY AND COMPLETENESS THEREOF IS NOT GUARANTEED.

STI TYPICALLY WARRANTIES ITS PRODUCTS FOR ONE FULL YEAR. FOR COMPLETE DETAILS OF OUR STANDARD WARRANTY, PLEASE VISIT WWW.STIFIRESTOP.COM/LEGAL/WARRANTY

MADE IN THE USA - © 2020 SPECIFIED TECHNOLOGIES INC.